

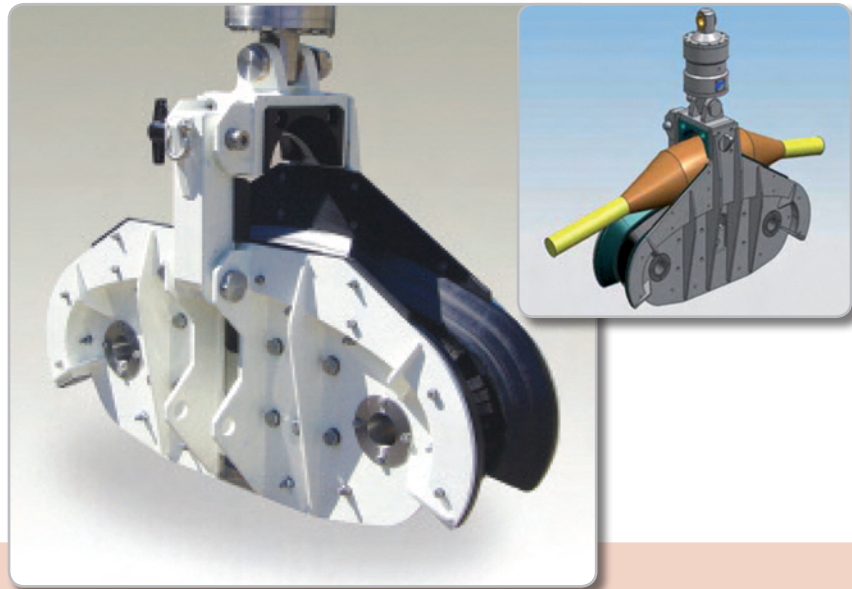

## Fairlead | 12.5 Tonne • 3 axis of Operation • Streamer Fairlead

- 12.5 tonne load (6 tonne line tension).
- 360° rotating swivel unit.
- 750mm effective bend radius over the belt surface.
- 0mm to 170mm cable or bend restrictor outer diameter passage capability.
- Custom profiled rubber belt to suit your cable diameters to ensure maximum cable care is obtained.



### The Seamap Fairlead offers safe and reliable cable handling for deployments/towing and recovery.

With a unique belt design which is profiled to suit the user's active sections and tow leaders this ensures the maximum cable contact is obtain at all times. The belt is profiled in 2 stages:

- **Primary** - Active Sections from 50mm to 70mm outer diameter.
- **Secondary** - Tow leader from 0mm to 50mm.

The final profile is formed to produce a linear envelope from 70mm to 170mm for cable or bend restrictor passage.

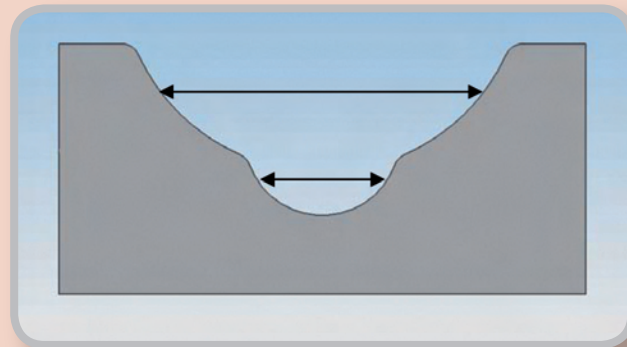

— Example cross section of a purpose machined belt.

# Fairlead

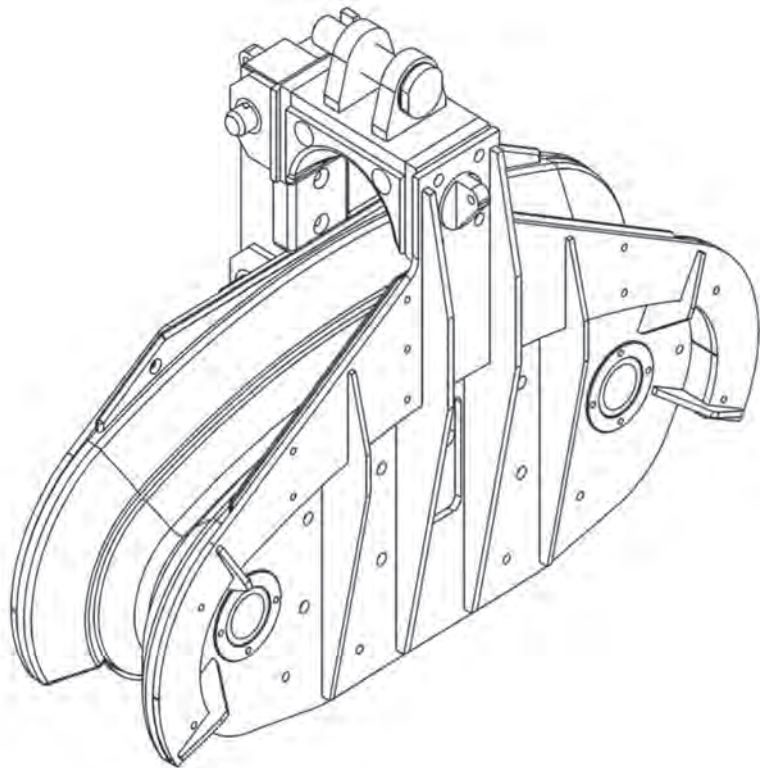
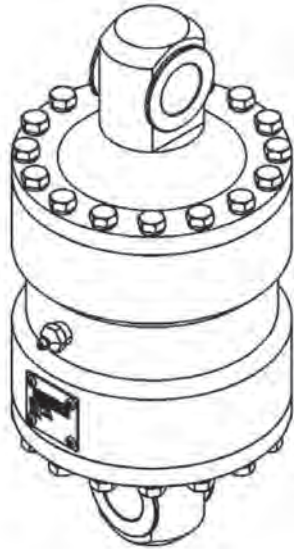

## Specifications

### Fairlead

Effective Bend Radius	750mm
Belt Profile	0mm to 70mm dual stage profile moulding
Belt Material	Rubber toothed for traction with tension adjustment
Load Capabilities (Line tension)	12.5 tonnes static / 6.25 tonnes dynamic
Size mm (L x H x W)	816 x 625 x 326
Weight	95 Kg

### Bearing Swivel Unit

Housing	Stainless Steel
Rotation Angles	360 Degrees
Size mm (H)	327
Diameter mm	150
Weight	20 Kg



### Seamap Inc.

PO Box 1175, Huntsville, TX. 77342  
 United States of America  
 Tel : +1 936 291 2277  
 Fax : +1 936 295 1922  
 Email : info-usa@seamap.com

### Seamap (UK) Ltd.

Unit 34, The Maltings, Charlton Estate  
 Shepton Mallet, Somerset, BA4 5QE, UK  
 Tel : +44 [0] 174 934 2223  
 Fax : +44 [0] 174 934 7588  
 Email : info-uk@seamap.com

### Seamap Pte Ltd.

51 Changi North Crescent  
 Singapore 499626  
 Tel : +65 6545 1054  
 Fax : +65 6545 0585  
 Email : info-asia@seamap.com